

RTU Installation Manual



STREAM-M
Monitoring RTUs



STREAM-C
Control RTUs



STREAM-A
Automated
Panels



Welcome to STREAMETRIC - STREAM Series

This Manual is intended to guide professionals through the installation of the STREAMETRIC STREAM-M/C/A RTU product line. Please read this document prior to installation and ensure that all necessary materials are present before beginning the installation process.

Visit <https://STREAMETRIC.io/support/> for further information, material and access to our support team.

Quick Start Guide



<p>Step by step:</p> <ol style="list-style-type: none"> 1. Locate power, signals, sensor placement 2. Mount unit 3. Run conduit 4. Measure, cut, label wire 5. Pull/land wire 6. Fill out signals table on enclosure 7. Scan here to request activation 	<p>Required Materials:</p> <ul style="list-style-type: none"> ✓ Mounting Hardware ✓ ¾" Flex or schedule 40 rigid conduit ✓ Conduit Fittings ✓ 18 AWG Stranded Wire (red, white, green, yellow, blue) ✓ 2 Conductor Shielded Cable ✓ Relays (site specific) 	<p>ONLY DRILL INTO BOTTOM OF ENCLOSURE! Seal conduit holes with duct seal</p>  
---	---	--

Power (110-240V)

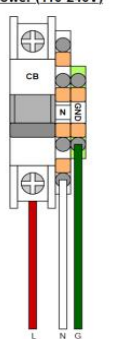

Digital Signals (12V Dry Contact)

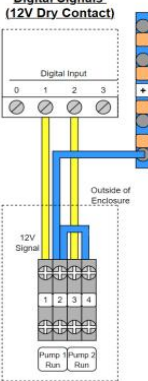

Digital Signals (120V Relay)

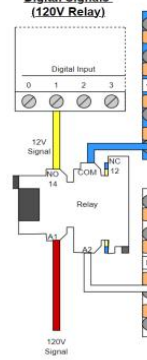

Analog Signals

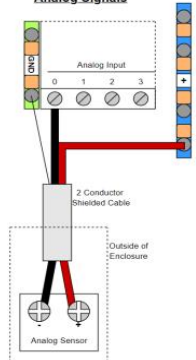

Copyright © 2026 by I2M, LLC. All rights reserved.

No part of this manual or accompanying software may be reproduced or transmitted in any form or by means, electronics or mechanical, including copying, recording or by any information storage and retrieval system, without permission in writing from I2M LLC.

I2M, LLC. DBA STREAMETRIC
801 Corporate Center Dr. Suite 128 Raleigh, NC 27607

www.STREAMETRIC.io

2

Contents

1	Product Overview.....	5
1.1	Hardware Included with RTUs	5
2	Unpacking and Inspection.....	7
3	Mounting Unit	7
3.1	Enclosure Unit.....	7
3.2	Non-Enclosure	8
4	Placing Antennas	9
5	Installing Conduit and Run Wires.....	10
6	Terminate Wires.....	12
6.1	Terminate IO.....	12
6.2	Connect Battery	13
6.3	Connect AC Power	15
6.4	Switch on Circuit Breaker	15
7	Testing IO	15
7.1	Digital and Analogs.....	15
7.2	Control Outputs (Command).....	16
8	Submit Onboarding Request.....	16
8.1	Onboarding Form	16
8.2	Required Information on Onboarding Form.....	17
8.3	Open STREAMETRIC App	17
9	Wire Termination Standards.....	18
9.1	STREAM-M 8-8-0-0 & 16-16-0-0	18
9.1.1	Lift Stations.....	18
9.1.2	Tanks and Towers.....	19
9.2	STREAM-C 16-8-6-4.....	21
9.2.1	Lift Stations.....	21
9.2.2	Valve Sites	23
9.2.3	Wells.....	25
9.3	STREAM-A 4-4-4-2	27
9.3.1	Valves Sites.....	27
9.3.2	Booster Stations.....	28

9.3.3	Wells.....	29
9.4	STREAM-A 20-12-10-16	30
9.4.1	Lift Stations.....	31
10	Instructions for Accessories.....	33
10.1	Relays.....	33
10.2	Current Transducers	34
10.3	Level transducers	34
10.4	Pressure transducers.....	35

1 Product Overview

1.1 Hardware Included with RTUs

- RTU (STREAM-M, STREAM-C or STREAM-A)
- Battery
- Quick Installation Guide
- Enclosure mounting kit
- Optional parts (if ordered):
 - External antenna & mounting kit
 - Relays
 - Level transducer
 - Pressure transducers
 - Current transducers
 - Pulse counting device (for rain tipping buckets)

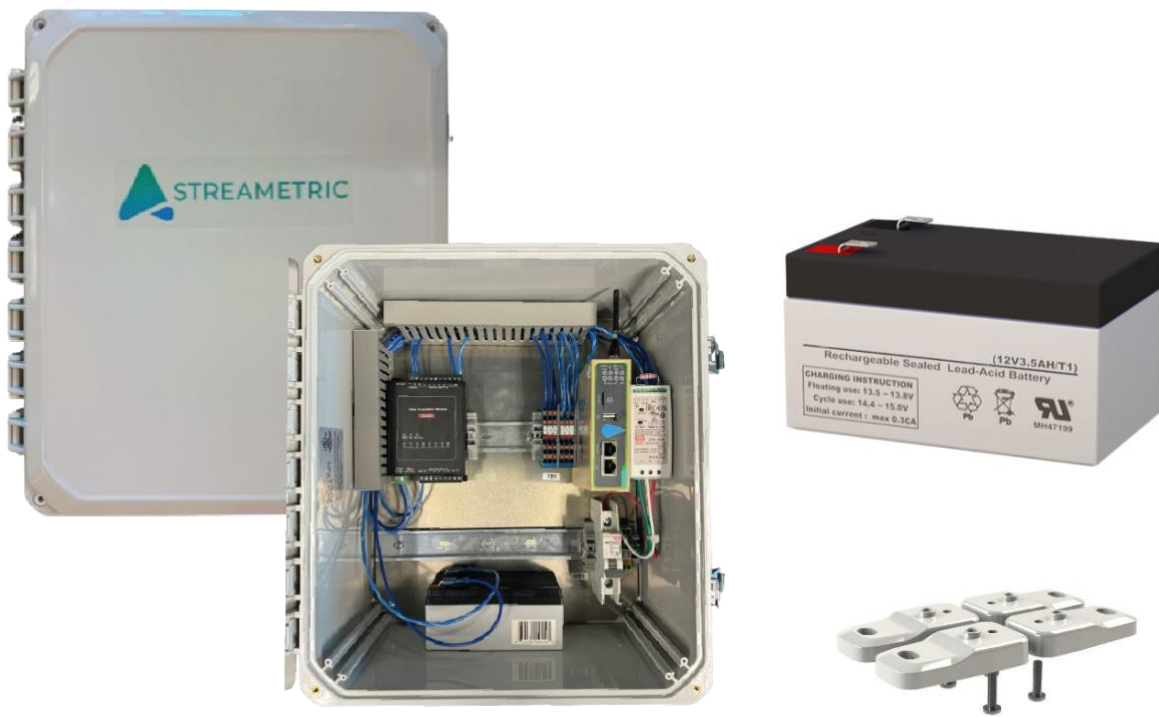

Recommended Tools and Materials (Not Included)

Mechanical Tools	Electrical Tools	Materials
Drill	Multimeter	16-gauge wire for digitals and power, shielded-twisted pair multi-conductor cable for analogs
Step drill bit or 3/4" hole saw	Wire cutters	12-14-gauge green wire for grounding the RTU
Reciprocating saw	Wire strippers	3/4" Flex conduit with straight and elbow fittings
Pliers		Unistrut rail and hardware for mounting
Nut Driver		
Phillips-head screwdriver		
Flat-head screwdriver		
Ladder		

2 Unpacking and Inspection

Each of our products is 100% quality tested but before moving forward with installation, please make sure the following are true to test that nothing was damaged during shipping. (Reference wiring instructions)

1. Inspect the enclosure for any cracks or damage.
2. Look for any loose wires
3. Make sure all components are securely mounted on the DIN rail.
(Heavy components such as the power supply may detach from the DIN rail during shipping)
4. Make sure the cellular antenna is connected to the gateway.
5. If no issues are found, proceed with the installation.

3 Mounting Unit

3.1 Enclosure Unit

The STREAMETRIC enclosure is mounted using the included mounting feet on each corner. These can be set up horizontally or vertically to accommodate different install scenarios. We recommend mounting the unit as close as possible to inputs/outputs and 120VAC power.

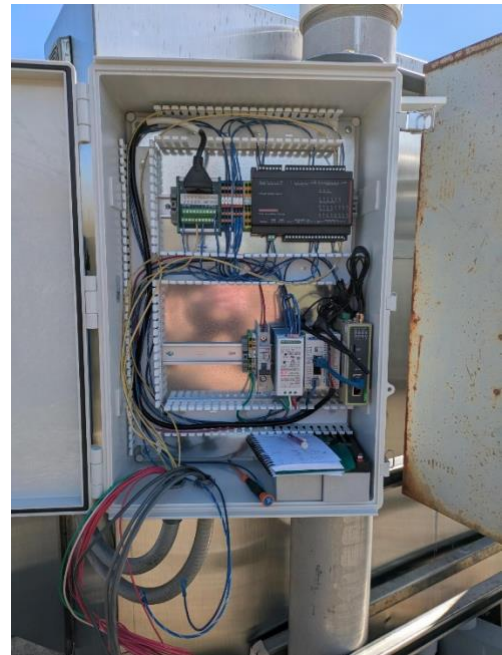

Example of a Mounted STREAMETRIC Unit with Enclosure

3.2 Non-Enclosure

Use self-tapping screws to attach our subpanel to the existing panel. Make sure to measure the amount of wiring required from the components on the main control to the STREAMETRIC unit to ensure a cleaner path to our unit.



Example of a Mounted STREAMETRIC Unit with No Enclosure Inside a Station's Main Control Panel

4 Placing Antennas

The STREAM unit comes preinstalled with internal antennas. By default, a SIM card is pre-installed to the SIM 1 slot, which is connected to the “Main Antenna” port. In case you need to reconnect them or change the antenna type, please do the following:

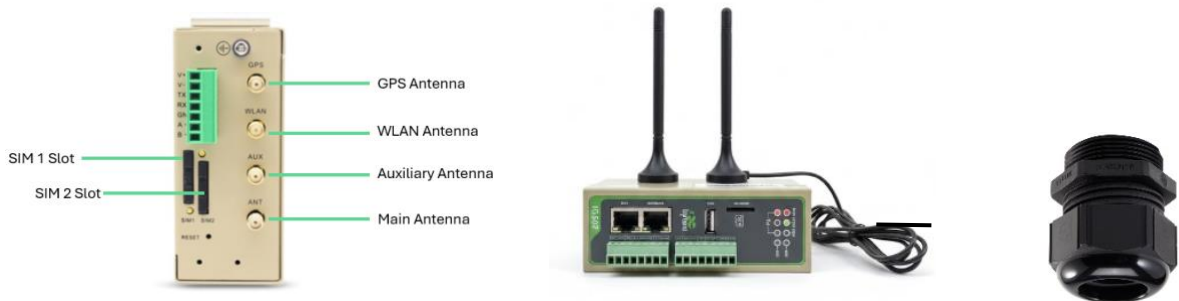

To install an external antenna, follow these steps:

- Drill hole for cable gland and route antenna cable outside (at the bottom of the panel)
- Connect the SMA antenna port (default: Main Antenna port)
- Mount the antenna upright, high and above all metal surfaces.
- Coil the excess cable in circles 5-7 inches in diameter and mount it on the inside of the enclosure.

NOTE: Optionally, when using a 2nd SIM card, insert it to the SIM 2 slot. The 2nd slot uses the “Auxillary Antenna” port. Contact STREAMETRIC support to set SIM settings.

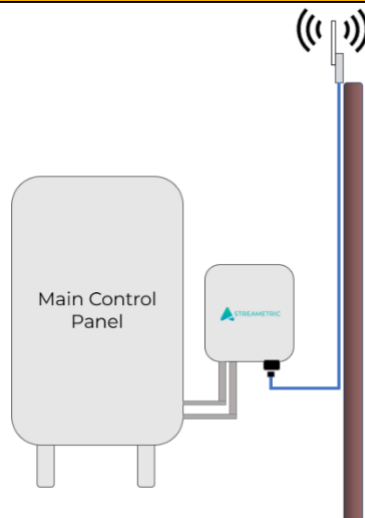

5 Installing Conduit and Run Wires



Example of how to run conduit from the bottom of the STREAMETRIC Enclosure to the Main Control Panel

- Run separate conduits for high & low voltage wires
- Measure wire length and cut wires
- Label each wire (both sides)
- Pull wires through conduits (Tipp: add spare wires as a buffer)

NOTE: Which conduit to select often depends on the project. Ensure you follow the requirements for the specific location. Common conduit materials are PVC or steel (either flexible or rigid)

120VAC power and digital signals may be run in the same conduit if they fit. Analog inputs (typically 12-24VDC) should be run in their own conduit to prevent interference. Consider the position of the holes to ensure there is enough room for the battery. Depending on the number of signals required for this site, the amount of wire to run from the main control panel to our unit might differ. As a rule of thumb, make sure to run the digital and power signals on the same line for easier wire management as well as preventing any electrical interference that could cause analog sensors from having incorrect readings.

NOTE: The digital inputs can be run together with the power supply coming from the main control panel. The analog signals **NEED** to run together in a separate conduit from the digital signals to prevent interference.

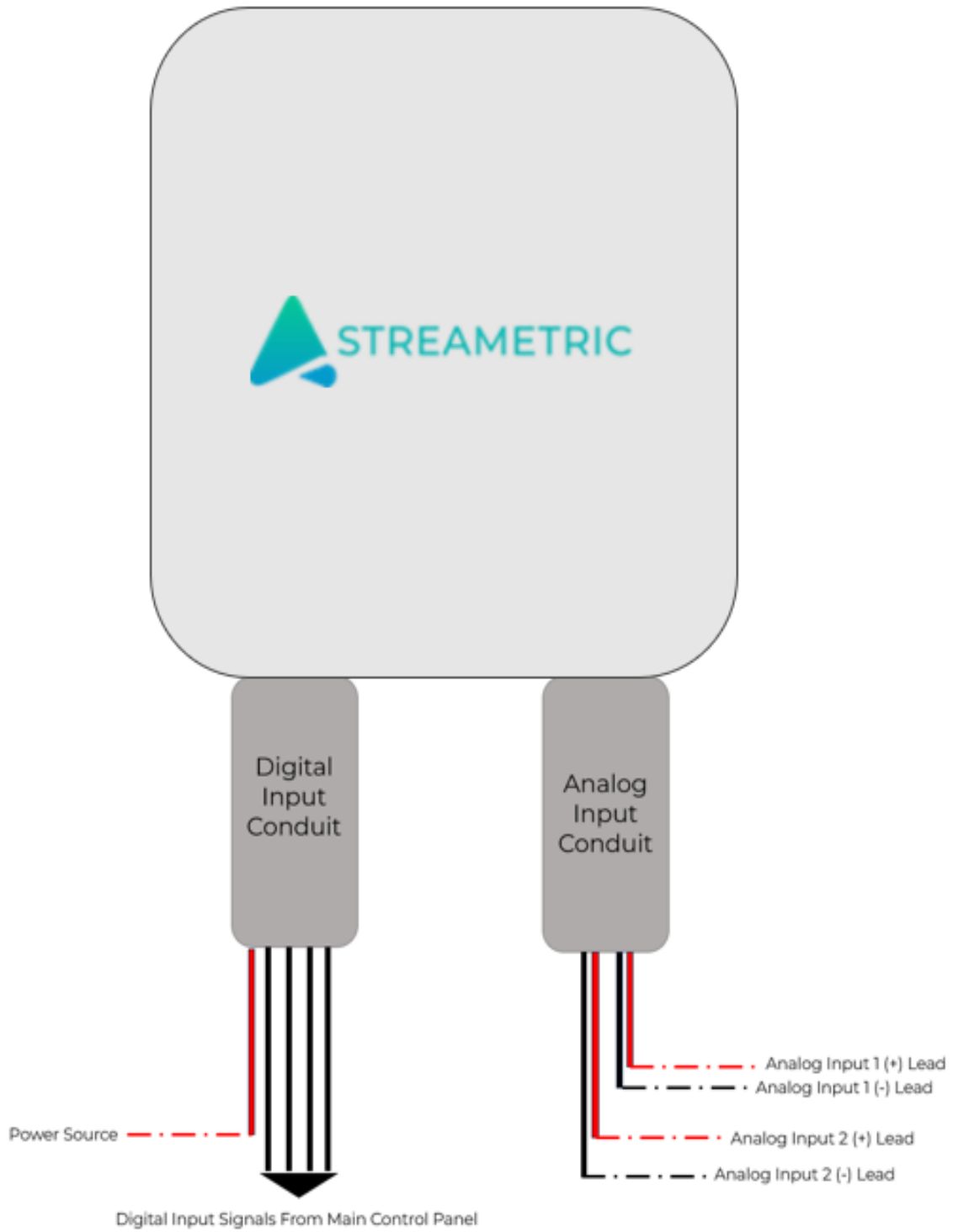

6 Terminate Wires

6.1 Terminate IO

For landing the IO wires, follow the **Wire Termination Standards (section 9)**, for your STREAMETRIC RTU Document wire number and signal lists on the IO table of the sticker in the enclosure door.

PORT	SIGNAL
DIO	Power Fail
DI1	
DI2	
DI3	
DI4	
DI5	
DI6	
DI7	
DI8	
DI9	
DI10	
DI11	
DI12	
DI13	
DI14	
DI15	
AI0	
AI1	
AI2	
AI3	
AI4	
AI5	
AI6	
AI7	
AI8	
AI9	
AI10	
AI11	
AI12	
AI13	
AI14	
AI15	

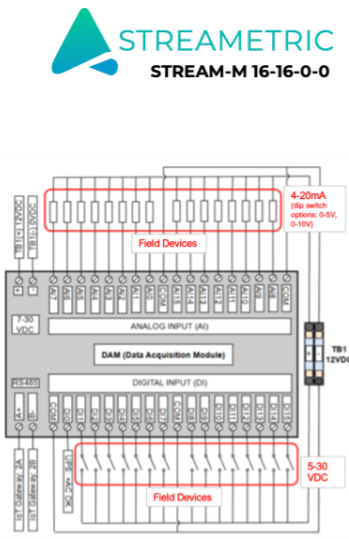

For device onboarding, documentation, and customer service please visit:



streametric.io/support

Example of a door sticker with a IO table

6.2 Connect Battery

Batteries must be connected for backup power, and the power fail alarm to work.

Connect battery cables that are pre-installed to the UPS/Power supply to the battery as follows:

- Solid blue cable to **(+)** terminal.
- Striped, white/blue cable to **(-)** terminal.

Below is a diagram of what the wiring will look like for the battery.

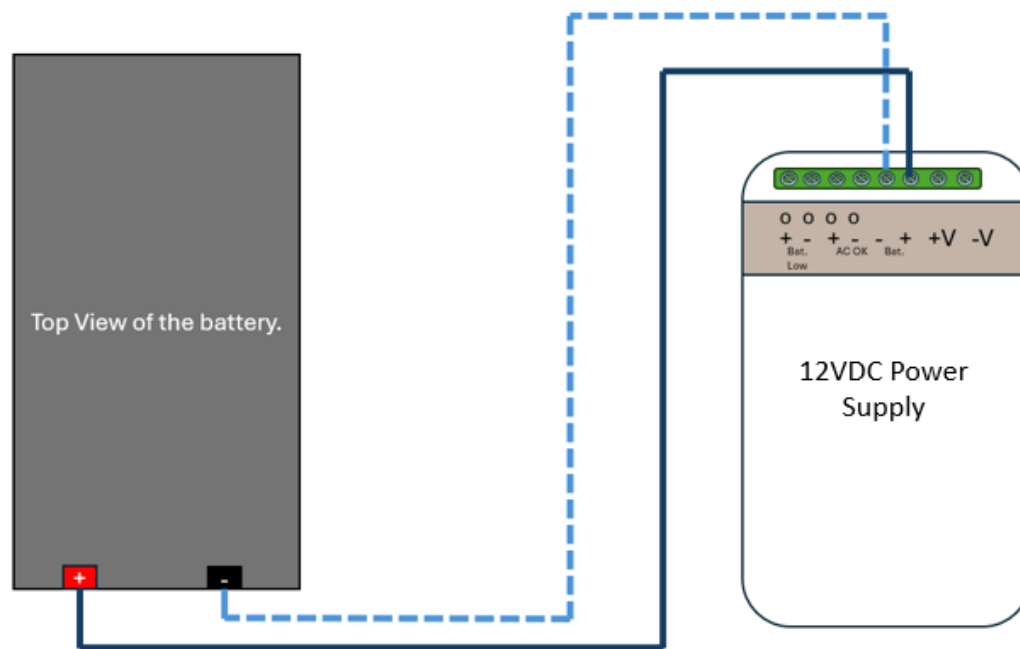

For the 24V option that comes included with STREAM-A Units, do the following:

- Solid blue cable to (+)
- Striped, white/blue cable to (-)
- Use the connector included with the unit to connect the 2 - 12V in series, connect the (+) and (-) leads across batteries.

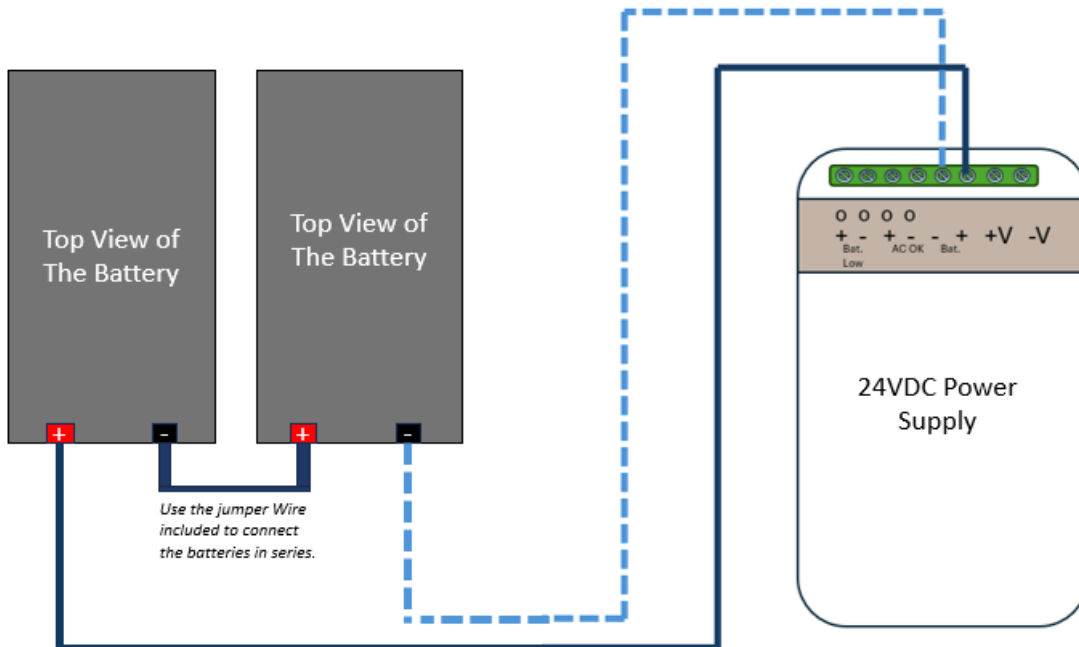

Disclaimer for products shipped to the EU

This product is designed in compliance with the EU Battery Regulation (EU) 2023/1542 for battery removability and user replacement. The battery backup cables are preinstalled on the unit. For products shipped to the EU, the rechargeable battery is not included and must be purchased separately from a third-party supplier. Ensure you obtain the compatible sealed lead acid battery (typical specification: 3.5Ah for 12V and 2x 3.5Ah for 24V RTU models)

No specialized tools are required for the installation or replacement of the battery, use common hand tools. Follow local regulations for disposal or recycling of used batteries, and the instructions provided by the battery supplier in compliance with the EU Battery Regulation.

6.3 Connect AC Power



Component	IO Label	Description	Wiring Instruction
TB1	Circuit Breaker	Acceptable input 120-240VAC	Positive
TB1	White (N)	Acceptable input 120-240VAC	Neutral
TB1	Green (GND)		Ground

6.4 Switch on Circuit Breaker

Once the switch on the circuit breaker has been flipped to the ON position, the STREAMETRIC unit will receive 120-240VAC input, and will provide power to the power supply.

7 Testing IO

7.1 Digital and Analogs

To ensure that digital and analog signals from field sensors are working correctly, follow these procedures:

- Digital Inputs (DI): To simulate a signal, use a jumper wire to bridge the Common (COM) terminal to the specific Input Point.

Note: Typically, this involves applying a +12/24VDC signal to the input. Upon successful bridging, the corresponding LED indicator on the module should turn red, confirming the loop is closed.

- (AI): Use a Multimeter or an Analog Signal Generator to simulate a transducer signal. Disconnect the sensor leads and connect the calibrator to the input terminals. Set the device to source a current loop (4-20mA or 0-20mA) consistent with the sensor's

calibrated range. Verify that the analog value reflected in the software matches the milliamp signal being sent.

7.2 Control Outputs (Command)

To validate that the system can successfully command field assets, test the output circuitry as follow:

- (DO): To test the switching logic, ensure the power source for the target asset (e.g., a motor starter or relay coil) is wired through the COM terminal of the DAM or Ziplink component. Then run a separate wire from the output terminal to the asset's control circuit. When a command is issued, the “DO” or “Y” status LED on the PLC/Module should turn red, and the physical asset should energize or de-energize accordingly.
- Analog Outputs (AO): To verify variable control (such as VFD speed or valve positioning), connect a multimeter in current-read mode to the analog output leads. Change the output value via the STREAMETRIC portal (e.g., set a value from 0-100%). The multimeter should show a proportional response (e.g., 4mA at 0% and 20mA at 100%).
- Once confirmed, re-connecting the leads to the physical actuator to ensure the asset behaves as commanded.

8 Submit Onboarding Request

8.1 Onboarding Form

Go to: <https://streametric.io/support-site-onboarding-form/>

- Fill out the form
- The STREAMETRIC support team will reach out to onboard the unit

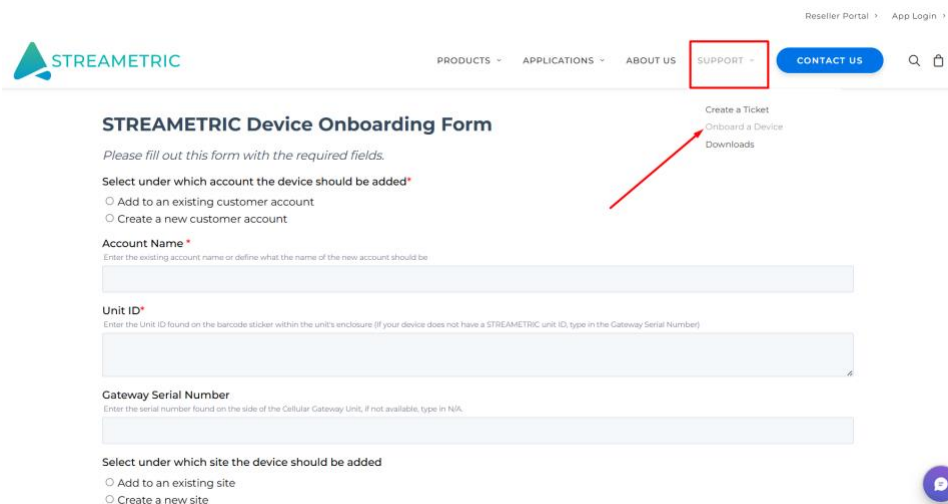

The screenshot shows the 'STREAMETRIC Device Onboarding Form' on a web page. The page header includes the STREAMETRIC logo, navigation links for PRODUCTS, APPLICATIONS, ABOUT US, and SUPPORT (highlighted with a red box), and a CONTACT US button. Below the header, the form title is 'STREAMETRIC Device Onboarding Form' with a sub-instruction: 'Please fill out this form with the required fields.' The form contains several sections: 'Select under which account the device should be added*' with radio buttons for 'Add to an existing customer account' and 'Create a new customer account'; 'Account Name*' with a text input field and a placeholder 'Enter the existing account name or define what the name of the new account should be'; 'Unit ID*' with a text input field and a placeholder 'Enter the Unit ID found on the barcode sticker within the unit's enclosure (if your device does not have a STREAMETRIC unit ID, type in the Gateway Serial Number)'; 'Gateway Serial Number' with a text input field and a placeholder 'Enter the serial number found on the side of the Cellular Gateway Unit, if not available, type in N/A.'; and 'Select under which site the device should be added' with radio buttons for 'Add to an existing site' and 'Create a new site'. A red arrow points from the 'SUPPORT' menu item to the 'Create a Ticket' link in the top right corner. A chat icon is visible in the bottom right corner.

Some of the items that the STREAMETRIC Support Team takes care of during the onboarding of a unit include:

- Activating cellular connectivity
- Linking the unit to the STREAMETRIC portal
- Testing signals for correct readings, scale sensors, and test outputs.
- Setting up the main Dashboard (Adding widgets and control features [if any])
- Add Users
- Creating alarms and notification groups based on customer's requests
- Mapping tags/data points to their respective unit
- Schedule training/onboarding sessions to have the end user become familiar with the platform.

8.2 Required Information on Onboarding Form

- **End User Organization Name:** This would be the name of the utility or company that requested our RTU to be installed at one of their sites.
- **Billing Admin E-mail Address:** The e-mail of the person responsible for billing purposes such as subscription renewal.
- **Billing Admin Phone Number:** The phone number of the person responsible for billing purposes such as subscription renewal.
- **Account Name:** Name of the Customer Account on the STREAMETRIC Application.
- **Unit ID:** STREAMETRIC Unit identifier usually starts with the manufacturing year, followed by the month, and the batch unit identifier. For example (251200010).
- **Gateway Serial Number:** This is the serial number of the STREAMETRIC Gateway device (InHand Gateway); it is located on the side sticker of the device and usually starts with a "GF"
- **Site Name:** Name for the Lift Station, Tower, Booster, where the STREAMETRIC unit is installed.
- **Site Address:** They physical address of where the STREAMETRIC unit is located. This can be a concrete physical address or a set of coordinates that include the longitude and latitude.
- **IO Signals List:** Picture of the IO sticker located on the door on our gateway with the information filled out as where wires were landed or a list of what signals we are reading from the main control panel.
- **First Name:** Name of the person requesting onboarding.
- **Last Name:** Last name of the person requesting onboarding.
- **Contact E-mail:** e-mail address of the person requesting onboarding.
- **Phone Number:** Phone number of the person requesting onboarding.

8.3 Open STREAMETRIC App

Once you the unit was assigned to your account, you can access it under the sites list on the STREAMETRIC app (<https://app.streametric.io/>)

9 Wire Termination Standards

9.1 STREAM-M 8-8-0-0 & 16-16-0-0

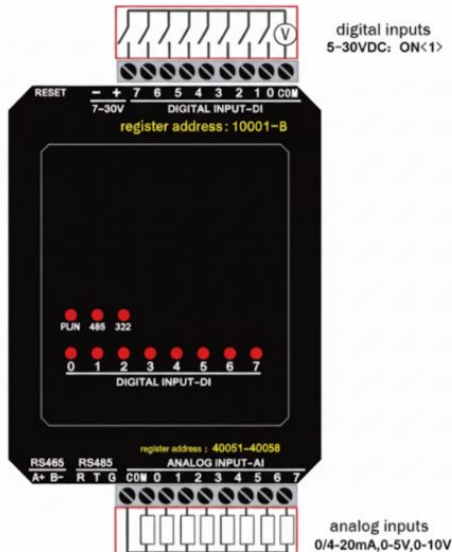

(DAM) Data Acquisition Module
STREAM-M 8-8-0-0

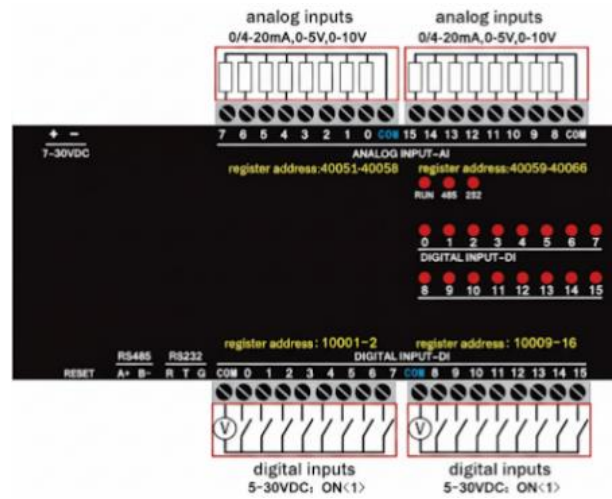

(DAM) Data Acquisition Module
STREAM-M 16-16-0-0

Important: Ensure that the acceptable input voltage is not exceeded. If your signals have a higher voltage, use appropriate relays to step them down. See section 10.1 for relay wiring examples.

9.1.1 Lift Stations

9.1.1.1 Digital Inputs

Component	IO Label	Description	Wiring Instruction
DAM	COM	Common for DI0-DI7	Connected to TB (-)
DAM	DI0	5-30VDC, Sinking	Battery/Power Alarm
DAM	DI1	5-30VDC, Sinking	Pump 1 Command
DAM	DI2	5-30VDC, Sinking	Pump 2 Command
DAM	DI3	5-30VDC, Sinking	Alarm Pump 1 - Seal Fail/Overtemp
DAM	DI4	5-30VDC, Sinking	Alarm Pump 2 - Seal Fail/Overtemp
DAM	DI5	5-30VDC, Sinking	High Level
DAM	DI6	5-30VDC, Sinking	Reserve
DAM	DI7	5-30VDC, Sinking	Reserve
DAM	COM	Common for DI8-DI15	Connected to TB (-)
DAM	DI8	5-30VDC, Sinking	Alarm Pump 2 - Seal Fail

Component	IO Label	Description	Wiring Instruction
DAM	DI9	5-30VDC, Sinking	Alarm Pump 2 - Over Temp
DAM	DI10	5-30VDC, Sinking	Alarm Pump 3 - Seal Fail
DAM	DI11	5-30VDC, Sinking	Alarm Pump 3 - Over Temp
DAM	DI12	5-30VDC, Sinking	Alarm Pump 4 - Seal Fail
DAM	DI13	5-30VDC, Sinking	Alarm Pump 4 - Over Temp
DAM	DI14	5-30VDC, Sinking	Alarm – Reserve – Pump Run Read
DAM	DI15	5-30VDC, Sinking	Alarm – Reserve - Pump Run Read

9.1.1.2 Analog Inputs

Component	IO Label	Description	Wiring Instruction
DAM	COM	Common for AI0-AI7	Connected to TB (-)
DAM	AI0	24VDC, 4-20mA	Level Transducer
DAM	AI1	24VDC, 4-20mA	Pump 1 Amps (Optional)
DAM	AI2	24VDC, 4-20mA	Pump 2 Amps (Optional)
DAM	AI3	24VDC, 4-20mA	Outlet Pressure (Optional)
DAM	AI4	24VDC, 4-20mA	Reserve
DAM	AI5	24VDC, 4-20mA	Reserve
DAM	AI6	24VDC, 4-20mA	Reserve
DAM	AI7	24VDC, 4-20mA	Reserve
DAM	AI8	24VDC, 4-20mA	Reserve
DAM	AI9	24VDC, 4-20mA	Reserve
DAM	AI10	24VDC, 4-20mA	Reserve
DAM	AI11	24VDC, 4-20mA	Reserve
DAM	AI12	Common for AI0-AI7	Reserve
DAM	AI13	24VDC, 4-20mA	Reserve
DAM	AI14	24VDC, 4-20mA	Reserve
DAM	AI15	24VDC, 4-20mA	Reserve

9.1.2 Tanks and Towers

9.1.2.1 Digital Inputs

Component	IO Label	Description	Wiring Instruction
DAM	COM	Common for DI0-DI7	Connected to TB (-)
DAM	DI0	5-30VDC, Sinking	Battery/Power Alarm
DAM	DI1	5-30VDC, Sinking	Reserve
DAM	DI2	5-30VDC, Sinking	Reserve
DAM	DI3	5-30VDC, Sinking	Reserve

Component	IO Label	Description	Wiring Instruction
DAM	DI4	5-30VDC, Sinking	Reserve
DAM	DI5	5-30VDC, Sinking	Reserve
DAM	DI6	5-30VDC, Sinking	Reserve
DAM	DI7	5-30VDC, Sinking	Reserve
DAM	COM	Common for DI8-DI15	Connected to TB (-)
DAM	DI8	5-30VDC, Sinking	Reserve
DAM	DI9	5-30VDC, Sinking	Reserve
DAM	DI10	5-30VDC, Sinking	Reserve
DAM	DI11	5-30VDC, Sinking	Reserve
DAM	DI12	5-30VDC, Sinking	Reserve
DAM	DI13	5-30VDC, Sinking	Reserve
DAM	DI14	5-30VDC, Sinking	Reserve
DAM	DI15	5-30VDC, Sinking	Reserve

9.1.2.2 Analog Inputs

Component	IO Label	Description	Wiring Instruction
DAM	COM	Common for AI0-AI7	Connected to TB (-)
DAM	AI0	24VDC, 4-20mA	Level Transducer
DAM	AI1	24VDC, 4-20mA	Reserve
DAM	AI2	24VDC, 4-20mA	Reserve
DAM	AI3	24VDC, 4-20mA	Reserve
DAM	AI4	24VDC, 4-20mA	Reserve
DAM	AI5	24VDC, 4-20mA	Reserve
DAM	AI6	24VDC, 4-20mA	Reserve
DAM	AI7	24VDC, 4-20mA	Reserve
DAM	AI8	24VDC, 4-20mA	Reserve
DAM	AI9	24VDC, 4-20mA	Reserve
DAM	AI10	24VDC, 4-20mA	Reserve
DAM	AI11	24VDC, 4-20mA	Reserve
DAM	AI12	Common for AI0-AI7	Reserve
DAM	AI13	24VDC, 4-20mA	Reserve
DAM	AI14	24VDC, 4-20mA	Reserve
DAM	AI15	24VDC, 4-20mA	Reserve

9.2 STREAM-C 16-8-6-4

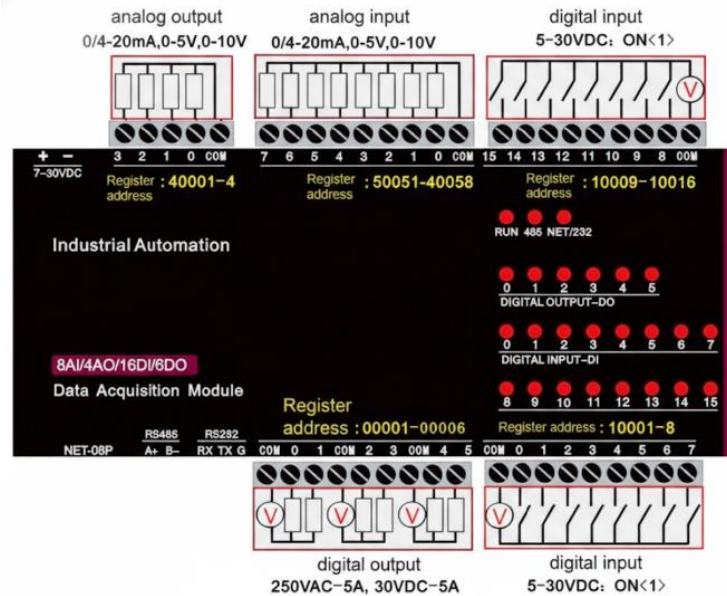

(DAM) Data Acquisition Module
STREAM-C 16-8-6-4

Important: Ensure that the acceptable input voltage is not exceeded. If your signals have a higher voltage, use appropriate relays to step it down. See section 10.1 for relay wiring examples.

9.2.1 Lift Stations

9.2.1.1 Digital Inputs

Component	IO Label	Description	Wiring Instruction
DAM	COM	Common for DI0-DI7	Connected to TB (-)
DAM	DI0	5-30VDC, Sinking	Battery/Power Alarm
DAM	DI1	5-30VDC, Sinking	Pump 1 Command
DAM	DI2	5-30VDC, Sinking	Pump 2 Command
DAM	DI3	5-30VDC, Sinking	Alarm Pump 1 - Seal Fail/Overtemp
DAM	DI4	5-30VDC, Sinking	Alarm Pump 2 - Seal Fail/Overtemp
DAM	DI5	5-30VDC, Sinking	Reserve
DAM	DI6	5-30VDC, Sinking	Reserve
DAM	DI7	5-30VDC, Sinking	Reserve
DAM	COM	Common for DI8-DI15	Connected to TB (-)
DAM	DI8	5-30VDC, Sinking	Reserve
DAM	DI9	5-30VDC, Sinking	Reserve
DAM	DI10	5-30VDC, Sinking	Reserve

Component	IO Label	Description	Wiring Instruction
DAM	DI11	5-30VDC, Sinking	Reserve
DAM	DI12	5-30VDC, Sinking	Reserve
DAM	DI13	5-30VDC, Sinking	Reserve
DAM	DI14	5-30VDC, Sinking	Reserve
DAM	DI15	5-30VDC, Sinking	Reserve

9.2.1.2 Analog Inputs

Component	IO Label	Description	Wiring Instruction
DAM	COM	Common for AI0-AI7	Connected to TB (-)
DAM	AI0	24VDC, 4-20mA	Pump 1 Discharge Pressure (Optional)
DAM	AI1	24VDC, 4-20mA	Pump 2 Discharge Pressure (Optional)
DAM	AI2	24VDC, 4-20mA	Pump 4 Discharge Pressure (Optional)
DAM	AI3	24VDC, 4-20mA	Pump 4 Discharge Pressure (Optional)
DAM	AI4	24VDC, 4-20mA	Pump 1 Amps (Optional)
DAM	AI5	24VDC, 4-20mA	Pump 2 Amps (Optional)
DAM	AI6	24VDC, 4-20mA	Pump 3 Amps (Optional)
DAM	AI7	24VDC, 4-20mA	Pump 4 Amps (Optional)

9.2.1.3 Digital Outputs

*** Note:** In the table it is assumed that the pump requires a 120V AC start signal, as this is most common in North America. Please ensure this is the correct voltage for your application.

Component	IO Label	Description	Wiring Instruction
DAM	COM	Common for DO0-DO1, up to 240 VAC/30VDC, 5A	Connect power source for output voltage
DAM	DO0	Relay, NO, Voltage depending on COM	Reserve
DAM	DO1	Relay, NO, Voltage depending on COM	Reserve
DAM	COM	Common for DO2-DO3, up to 240 VAC/30VDC, 5A	Connect power source for output voltage
DAM	DO2	Relay, NO, Voltage depending on COM	Reserve
DAM	DO3	Relay, NO, Voltage depending on COM	Reserve
DAM	COM	Common for DO4-DO5, up to 240 VAC/30VDC, 5A	Connect power source for output voltage
DAM	DO4	Relay, NO, Voltage depending on COM	Reserve
DAM	DO5	Relay, NO, Voltage depending on COM	Reserve

9.2.1.4 Analog Outputs

Component	IO Label	Description	Wiring Instruction
DAM	AO0	24VDC, 4-20mA	Pump 1 Speed Output (to VFD +AI) - Optional
DAM	AO1	24VDC, 4-20mA	Pump 2 Speed Output (to VFD +AI) - Optional
DAM	AO2	24VDC, 4-20mA	Pump 3 Speed Output (to VFD +AI) - Optional
DAM	AO3	24VDC, 4-20mA	Pump 4 Speed Output (to VFD +AI) - Optional

9.2.2 Valve Sites

9.2.2.1 Digital Inputs

Important: Ensure that the acceptable input voltage is not exceeded. If your signals have a higher voltage, use appropriate relays to step it down.

Component	IO Label	Description	Wiring Instruction
DAM	COM	Common for DI0-DI7	Connected to TB (-)
DAM	DI0	5-30VDC, Sinking	Battery/Power Alarm
DAM	DI1	5-30VDC, Sinking	Valve 1 Open (Optional)
DAM	DI2	5-30VDC, Sinking	Valve 1 Close (Optional)
DAM	DI3	5-30VDC, Sinking	Valve 2 Open (Optional)
DAM	DI4	5-30VDC, Sinking	Valve 2 Close (Optional)
DAM	DI5	5-30VDC, Sinking	Reserve
DAM	DI6	5-30VDC, Sinking	Reserve
DAM	DI7	5-30VDC, Sinking	Reserve
DAM	COM	Common for DI8-DI15	Connected to TB (-)
DAM	DI8	5-30VDC, Sinking	Reserve
DAM	DI9	5-30VDC, Sinking	Reserve
DAM	DI10	5-30VDC, Sinking	Reserve
DAM	DI11	5-30VDC, Sinking	Reserve
DAM	DI12	5-30VDC, Sinking	Reserve
DAM	DI13	5-30VDC, Sinking	Reserve
DAM	DI14	5-30VDC, Sinking	Reserve
DAM	DI15	5-30VDC, Sinking	Reserve

9.2.2.2 Analog Inputs

Component	IO Label	Description	Wiring Instruction
DAM	COM	Common for AI0-AI7	Connected to TB (-)
DAM	AI0	24VDC, 4-20mA	Level Transducer
DAM	AI1	24VDC, 4-20mA	Reserve
DAM	AI2	24VDC, 4-20mA	Reserve
DAM	AI3	24VDC, 4-20mA	Reserve
DAM	AI4	24VDC, 4-20mA	Reserve
DAM	AI5	24VDC, 4-20mA	Reserve
DAM	AI6	24VDC, 4-20mA	Reserve
DAM	AI7	24VDC, 4-20mA	Reserve

9.2.2.3 Digital Outputs

*** Note:** In the table it is assumed that the pump requires a 120V AC start signal, as this is most common in North America. Please ensure this is the correct voltage for your application.

Component	IO Label	Description	Wiring Instruction
DAM	COM	Common for DO0-DO1, up to 240 VAC/30VDC, 5A	Connect to 120-240VAC/12-24VDC before Breaker
DAM	DO0	Relay, NO, Voltage depending on COM	Valve Command (to Valve Starter/Relay), 120VAC*
DAM	DO1	Relay, NO, Voltage depending on COM	Reserve
DAM	COM	Common for DO2-DO3, up to 240 VAC/30VDC, 5A	Connect to 120-240VAC/12-24VDC before Breaker
DAM	DO2	Relay, NO, Voltage depending on COM	Reserve
DAM	DO3	Relay, NO, Voltage depending on COM	Reserve
DAM	COM	Common for DO4-DO5, up to 240 VAC/30VDC, 5A	Connect to 120-240VAC/12-24VDC before Breaker
DAM	DO4	Relay, NO, Voltage depending on COM	Reserve
DAM	DO5	Relay, NO, Voltage depending on COM	Reserve

9.2.2.4 Analog Outputs

Component	IO Label	Description	Wiring Instruction
DAM	AO0	24VDC, 4-20mA	Reserve
DAM	AO1	24VDC, 4-20mA	Reserve
DAM	AO2	24VDC, 4-20mA	Reserve
DAM	AO3	24VDC, 4-20mA	Reserve

9.2.3 Wells

9.2.3.1 Digital Inputs

Important: Ensure that the acceptable input voltage is not exceeded. If your signals have a higher voltage, use appropriate relays to step it down.

Component	IO Label	Description	Wiring Instruction
DAM	COM	Common for DI0-DI7	Connected to TB (-)
DAM	DI0	5-30VDC, Sinking	Battery/Power Alarm
DAM	DI1	5-30VDC, Sinking	Well Pump Start Command/Status
DAM	DI2	5-30VDC, Sinking	Reserve
DAM	DI3	5-30VDC, Sinking	Reserve
DAM	DI4	5-30VDC, Sinking	Reserve
DAM	DI5	5-30VDC, Sinking	Reserve
DAM	DI6	5-30VDC, Sinking	Reserve
DAM	DI7	5-30VDC, Sinking	Reserve
DAM	COM	Common for DI8-DI15	Connected to TB (-)
DAM	DI8	5-30VDC, Sinking	Reserve
DAM	DI9	5-30VDC, Sinking	Reserve
DAM	DI10	5-30VDC, Sinking	Reserve
DAM	DI11	5-30VDC, Sinking	Reserve
DAM	DI12	5-30VDC, Sinking	Reserve
DAM	DI13	5-30VDC, Sinking	Reserve
DAM	DI14	5-30VDC, Sinking	Reserve
DAM	DI15	5-30VDC, Sinking	Reserve

9.2.3.2 Analog Inputs

Component	IO Label	Description	Wiring Instruction
DAM	COM	Common for AI0-AI7	Connected to TB (-)
DAM	AI0	24VDC, 4-20mA	Level Transducer
DAM	AI1	24VDC, 4-20mA	Reserve
DAM	AI2	24VDC, 4-20mA	Reserve
DAM	AI3	24VDC, 4-20mA	Reserve
DAM	AI4	24VDC, 4-20mA	Reserve
DAM	AI5	24VDC, 4-20mA	Reserve
DAM	AI6	24VDC, 4-20mA	Reserve
DAM	AI7	24VDC, 4-20mA	Reserve

9.2.3.3 Digital Outputs

*** Note:** In the table it is assumed that the pump requires a 120V AC start signal, as this is most common in North America. Please ensure this is the correct voltage for your application.

Component	IO Label	Description	Wiring Instruction
DAM	COM	Common for DO0-DO1, up to 240 VAC/30VDC, 5A	Connect to 120-240VAC/12-24VDC before Breaker
DAM	DO0	Relay, NO, Voltage depending on COM	Well Pump Starter (to Valve Starter/Relay), 120VAC*
DAM	DO1	Relay, NO, Voltage depending on COM	Reserve
DAM	COM	Common for DO2-DO3, up to 240 VAC/30VDC, 5A	Connect to 120-240VAC/12-24VDC before Breaker
DAM	DO2	Relay, NO, Voltage depending on COM	Reserve
DAM	DO3	Relay, NO, Voltage depending on COM	Reserve
DAM	COM	Common for DO4-DO5, up to 240 VAC/30VDC, 5A	Connect to 120-240VAC/12-24VDC before Breaker
DAM	DO4	Relay, NO, Voltage depending on COM	Reserve
DAM	DO5	Relay, NO, Voltage depending on COM	Reserve

9.2.3.4 Analog Outputs

Component	IO Label	Description	Wiring Instruction
DAM	AO0	24VDC, 4-20mA	Reserve
DAM	AO1	24VDC, 4-20mA	Reserve
DAM	AO2	24VDC, 4-20mA	Reserve
DAM	AO3	24VDC, 4-20mA	Reserve

9.3 STREAM-A 4-4-4-2



(DAM) ZIP Link

Important: Ensure that the acceptable input voltage is not exceeded. If your signals have a higher voltage, use appropriate relays to step it down.

9.3.1 Valves Sites

9.3.1.1 Digital Inputs

Component	IO Label	Description	Wiring Instruction
ZIP	C1	Common for X1-X4	Connected to TB (-)
ZIP	X1	24VDC, Sinking/Sourcing	Battery/Power Alarm
ZIP	X2	24VDC, Sinking/Sourcing	Flow Meter (Pulse Output) - Optional
ZIP	X3	24VDC, Sinking/Sourcing	Rain Tipping Bucket (Pulse Output) - Optional
ZIP	X4	24VDC, Sinking/Sourcing	Reserve

9.3.1.2 Analog Inputs

Component	IO Label	Description	Wiring Instruction
ZIP	ACOM	Common for AD1-AD4	Connected to TB (-)
ZIP	AD1	24VDC, 4-20mA	Level Transducer
ZIP	AD2	24VDC, 4-20mA	Flow Meter (Analog Input) - Optional
ZIP	AD3	24VDC, 4-20mA	Reserve
ZIP	AD4	24VDC, 4-20mA	Reserve

9.3.1.3 Digital Outputs

Note: In the table it is assumed that the pump requires a 120V AC start signal, as this is most common in North America. Please ensure this is the correct voltage for your application.

Component	IO Label	Description	Wiring Instruction
ZIP	C2	Common for Y1-Y4, 6-240 VAC/6-27 VDC, 5A	Connect to 120VAC before Breaker*
ZIP	Y1	Relay, NO, Voltage depending on C2	Valve Command (to Valve Starter/Relay), 120VAC*
ZIP	Y2	Relay, NO, Voltage depending on C2	Reserve
ZIP	Y3	Relay, NO, Voltage depending on C2	Reserve
ZIP	Y4	Relay, NO, Voltage depending on C2	Reserve

9.3.1.4 Analog Outputs

Component	IO Label	Description	Wiring Instruction
ZIP	ACOM	Common for DA1-DA2	Connected to TB (-)
ZIP	DA+V	Power for DA1-DA2 (24VDC)	Connected to TB (+)
ZIP	DA1	24VDC, 4-20mA	Reserve
ZIP	DA2	24VDC, 4-20mA	Reserve

9.3.2 Booster Stations

9.3.2.1 Digital Inputs

Component	IO Label	Description	Wiring Instruction
ZIP	C1	Common for X1-X4	Connected to TB (-)
ZIP	X1	24VDC, Sinking/Sourcing	Battery/Power Alarm
ZIP	X2	24VDC, Sinking/Sourcing	Pump 1 Seal Fail/High Temp
ZIP	X3	24VDC, Sinking/Sourcing	Pump 2 Seal Fail/High Temp
ZIP	X4	24VDC, Sinking/Sourcing	Reserve

9.3.2.2 Analog Inputs

Component	IO Label	Description	Wiring Instruction
ZIP	ACOM	Common for AD1-AD4	Connected to TB (-)
ZIP	AD1	24VDC, 4-20mA	Level/Pressure (Target Tank/Outlet)
ZIP	AD2	24VDC, 4-20mA	Pump 1 Amps (Optional)
ZIP	AD3	24VDC, 4-20mA	Pump 2 Amps (Optional)
ZIP	AD4	24VDC, 4-20mA	Feed Pressure (Optional)

9.3.2.3 Digital Outputs

*** Note:** In the table it is assumed that the pump requires a 120V AC start signal, as this is most common in North America. Please ensure this is the correct voltage for your application.

Component	IO Label	Description	Wiring Instruction
ZIP	C2	Common for Y1-Y4, 6-240 VAC/6-27 VDC, 5A	Connect to 120VAC before Breaker*
ZIP	Y1	Relay, NO, Voltage depending on C2	Pump 1 Command (to Pump Starter/Relay), 120VAC
ZIP	Y2	Relay, NO, Voltage depending on C2	Pump 2 Command (to Pump Starter/Relay), 120VAC
ZIP	Y3	Relay, NO, Voltage depending on C2	Chemical Dosing Pump Command, 120AV (Optional)
ZIP	Y4	Relay, NO, Voltage depending on C2	Reserve

9.3.2.4 Analog Outputs

Component	IO Label	Description	Wiring Instruction
ZIP	DA+V	Power for DA1-DA2 (24VDC)	Connected to TB (+)
ZIP	ACOM	Common for DA1-DA2	Connected to TB (-)
ZIP	DA1	24VDC, 4-20mA	Reserve
ZIP	DA2	24VDC, 4-20mA	Reserve

9.3.3 Wells

9.3.3.1 Digital Inputs

Component	IO Label	Description	Wiring Instruction
ZIP	C1	Common for X1-X4	Connected to TB (-)
ZIP	X1	24VDC, Sinking/Sourcing	Battery/Power Alarm
ZIP	X2	24VDC, Sinking/Sourcing	Reserve
ZIP	X3	24VDC, Sinking/Sourcing	Reserve
ZIP	X4	24VDC, Sinking/Sourcing	Reserve

9.3.3.2 Analog Inputs

Component	IO Label	Description	Wiring Instruction
ZIP	ACOM	Common for AD1-AD4	Connected to TB (-)
ZIP	AD1	24VDC, 4-20mA	Level Transducer
ZIP	AD2	24VDC, 4-20mA	Reserve
ZIP	AD3	24VDC, 4-20mA	Reserve
ZIP	AD4	24VDC, 4-20mA	Reserve

9.3.3.3 Digital Outputs

Note: In the table it is assumed that the pump requires a 120V AC start signal, as this is most common in North America. Please ensure this is the correct voltage for your application.

Component	IO Label	Description	Wiring Instruction
ZIP	C2	Common for Y1-Y4, 6-240 VAC/6-27 VDC, 5A	Connect to 120VAC before Breaker*
ZIP	Y1	Relay, NO, Voltage depending on C2	Well Pump Starter (to Starter/Relay), 120VAC*
ZIP	Y2	Relay, NO, Voltage depending on C2	Reserve
ZIP	Y3	Relay, NO, Voltage depending on C2	Reserve
ZIP	Y4	Relay, NO, Voltage depending on C2	Reserve

9.3.3.4 Analog Outputs

Component	IO Label	Description	Wiring Instruction
ZIP	ACOM	Common for DA1-DA2	Connected to TB (-)
ZIP	DA+V	Power for DA1-DA2 (24VDC)	Connected to TB (+)
ZIP	DA1	24VDC, 4-20mA	Reserve
ZIP	DA2	24VDC, 4-20mA	Reserve

9.4 STREAM-A 20-12-10-16

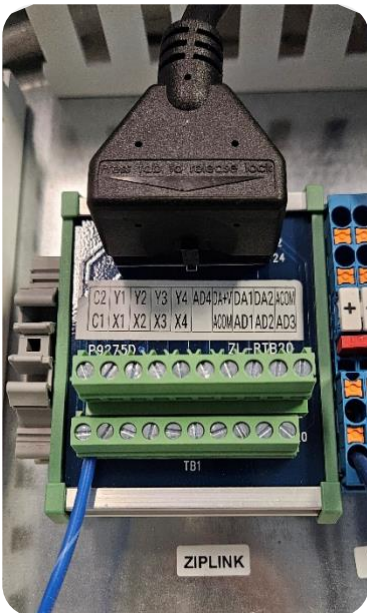

(DAM) ZIP Link

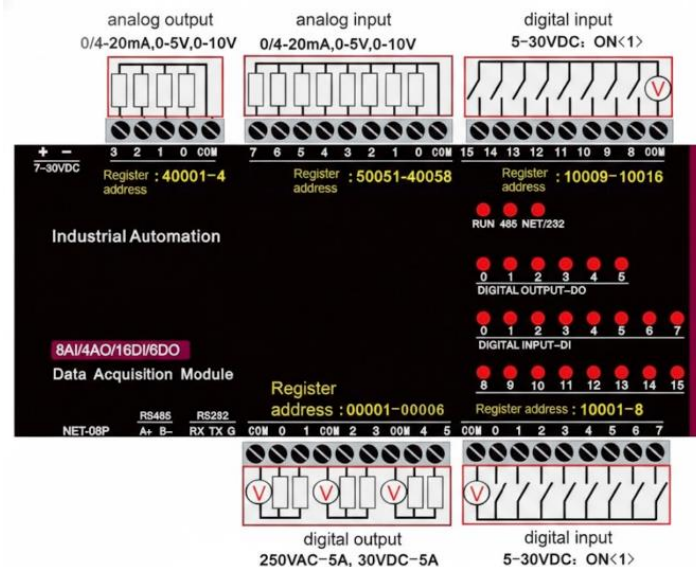

(DAM) Data Acquisition Module
STREAM-C 16-8-6-4

Important: Ensure that the acceptable input voltage is not exceeded. If your signals have a higher voltage, use appropriate relays to step it down.

9.4.1 Lift Stations

9.4.1.1 Digital Input

Component	IO Label	Description	Wiring Instruction
ZIP	C1	Common for X1-X4	Connected to TB (-)
ZIP	X1	24VDC, Sinking/Sourcing	Flow Meter (Pulse Output) - Optional
ZIP	X2	24VDC, Sinking/Sourcing	Rain Tipping Bucket (Pulse Output) - Optional
ZIP	X3	24VDC, Sinking/Sourcing	Off Float
ZIP	X4	24VDC, Sinking/Sourcing	High Float
DAM	COM	Common for DI0-DI7	Connected to TB (-)
DAM	DI0	5-30VDC, Sinking	Battery/Power Alarm
DAM	DI1	5-30VDC, Sinking	Low Float
DAM	DI2	5-30VDC, Sinking	Lead Float
DAM	DI3	5-30VDC, Sinking	Lag 1 Float
DAM	DI4	5-30VDC, Sinking	Lag 2 Float
DAM	DI5	5-30VDC, Sinking	Lag 3 Float
DAM	DI6	5-30VDC, Sinking	Alarm Pump 1 - Seal Fail
DAM	DI7	5-30VDC, Sinking	Alarm Pump 1 - Over Temp
DAM	COM	Common for DI8-DI15	Connected to TB (-)
DAM	DI8	5-30VDC, Sinking	Alarm Pump 2 - Seal Fail
DAM	DI9	5-30VDC, Sinking	Alarm Pump 2 - Over Temp
DAM	DI10	5-30VDC, Sinking	Alarm Pump 3 - Seal Fail
DAM	DI11	5-30VDC, Sinking	Alarm Pump 3 - Over Temp
DAM	DI12	5-30VDC, Sinking	Alarm Pump 4 - Seal Fail
DAM	DI13	5-30VDC, Sinking	Alarm Pump 4 - Over Temp
DAM	DI14	5-30VDC, Sinking	Alarm - Reserve - Pump Run Read
DAM	DI15	5-30VDC, Sinking	Alarm - Reserve - Pump Run Read

9.4.1.2 Analog Inputs

Component	IO Label	Description	Wiring Instruction
ZIP	ACOM	Common for AD1-AD4	Connected to TB (-)
ZIP	AD1	24VDC, 4-20mA	Level Transducer
ZIP	AD2	24VDC, 4-20mA	Flow Meter (Analog Output) - Optional
ZIP	AD3	24VDC, 4-20mA	Reserve
ZIP	AD4	24VDC, 4-20mA	Reserve
DAM	COM	Common for AI0-AI7	Connected to TB (-)
DAM	AI0	24VDC, 4-20mA	Pump 1 Discharge Pressure (Optional)

Component	IO Label	Description	Wiring Instruction
DAM	AI1	24VDC, 4-20mA	Pump 2 Discharge Pressure (Optional)
DAM	AI2	24VDC, 4-20mA	Pump 4 Discharge Pressure (Optional)
DAM	AI3	24VDC, 4-20mA	Pump 4 Discharge Pressure (Optional)
DAM	AI4	24VDC, 4-20mA	Pump 1 Amps (Optional)
DAM	AI5	24VDC, 4-20mA	Pump 2 Amps (Optional)
DAM	AI6	24VDC, 4-20mA	Pump 3 Amps (Optional)
DAM	AI7	24VDC, 4-20mA	Pump 4 Amps (Optional)

9.4.1.3 Digital Outputs

*** Note:** In the table it is assumed that the pump requires a 120V AC start signal, as this is most common in North America. Please ensure this is the correct voltage for your application.

Component	IO Label	Description	Wiring Instruction
ZIP	C2	Common for Y1-Y4, 6-240 VAC/6-27 VDC, 5A	Connect to 120VAC before Breaker*
ZIP	Y1	Relay, NO, Voltage depending on C2	Pump 1 Command (to Pump Starter/Relay), 120VAC*
ZIP	Y2	Relay, NO, Voltage depending on C2	Pump 2 Command (to Pump Starter/Relay), 120VAC*
ZIP	Y3	Relay, NO, Voltage depending on C2	Pump 3 Command (to Pump Starter/Relay), 120VAC*
ZIP	Y4	Relay, NO, Voltage depending on C2	Pump 4 Command (to Pump Starter/Relay), 120VAC*
DAM	COM	Common for DO0-DO1, up to 240 VAC/30VDC, 5A	Connect power source for output voltage
DAM	DO0	Relay, NO, Voltage depending on COM	Reserve
DAM	DO1	Relay, NO, Voltage depending on COM	Reserve
DAM	COM	Common for DO2-DO3, up to 240 VAC/30VDC, 5A	Connect power source for output voltage
DAM	DO2	Relay, NO, Voltage depending on COM	Reserve
DAM	DO3	Relay, NO, Voltage depending on COM	Reserve
DAM	COM	Common for DO4-DO5, up to 240 VAC/30VDC, 5A	Connect power source for output voltage
DAM	DO4	Relay, NO, Voltage depending on COM	Reserve
DAM	DO5	Relay, NO, Voltage depending on COM	Reserve

9.4.1.4 Analog Outputs

Component	IO Label	Description	Wiring Instruction
ZIP	DA+V	Power for DA1-DA2 (24VDC)	Connected to TB (+)
ZIP	DA1	24VDC, 4-20mA	Reserve
ZIP	DA2	24VDC, 4-20mA	Reserve
ZIP	ACOM	Common for DA1-DA2	Connected to TB (-)
DAM	AOCOM	Common for AO0-AO3	Connected to TB (-)
DAM	AO0	24VDC, 4-20mA	Pump 1 Speed Output (to VFD +AI) - Optional
DAM	AO1	24VDC, 4-20mA	Pump 2 Speed Output (to VFD +AI) - Optional
DAM	AO2	24VDC, 4-20mA	Pump 3 Speed Output (to VFD +AI) - Optional
DAM	AO3	24VDC, 4-20mA	Pump 4 Speed Output (to VFD +AI) - Optional

10 Instructions for Accessories

10.1 Relays

For digital inputs outside the voltage range supported by the IO modules, appropriate relays will be needed (can be purchased from STREAMETRIC). These can be mounted on the extra din rail space provided in the enclosure.

Instructions for relays provided by STREAMETRIC:

The input signal wire will connect to the A1 terminal on relay. (Note: make sure to complete the circuit by connecting neutral to A2 for 120 V AC, or ground to A2 for 12 – 24 V DC.) Connect the NO (14) port to + and the NC (12) port to -. The COM (13) port connects to the digital input on the CWT for the input you are monitoring.

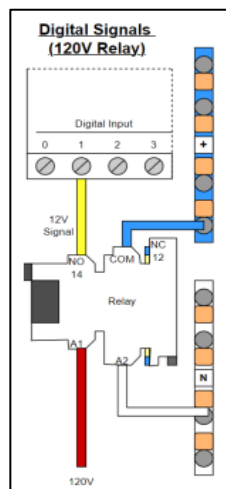

10.2 Current Transducers

Install the current transducer around the wire that needs to be monitored. (On a three-phase pump, any of the three phases may be monitored, but DO NOT use the neutral wire.) Power should be taken from the + terminal block on the STREAMETRIC unit and connect to the + terminal of the AC Current Transducer. The – terminal of the AC current transducer connects to the analog terminal on the io card. To complete the circuit, connect terminal block C1 to the – terminal block inside the STREAMETRIC RTU. (Note: DO NOT connect the negative terminal on the current transducer to the negative terminal block inside the STREAMETRIC RTU.) The second current transducer is set up the same way, but the negative terminal of the current transducer connects to A2 instead of A1. (Note: If only setting up A2 make sure the connection between C1 and the – terminal block on the STREAMETRIC RTU is still made.)

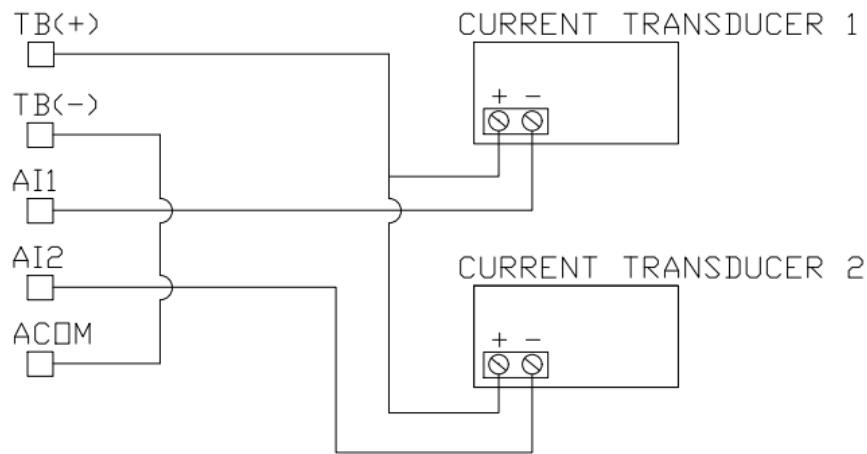

10.3 Level transducers

The end of the level transducer has one red wire, one black wire, one striped wire, and a plastic tube. The red wire connects to the + terminal block on the STREAMETRIC RTU, the black wire connects to A3, and the stripped wire connects to ground. The plastic tube is a bellows and can be left unconnected in the STREAMETRIC RTU. Lastly make a connection between C2 and the – terminal block inside the STREAMETRIC RTU.

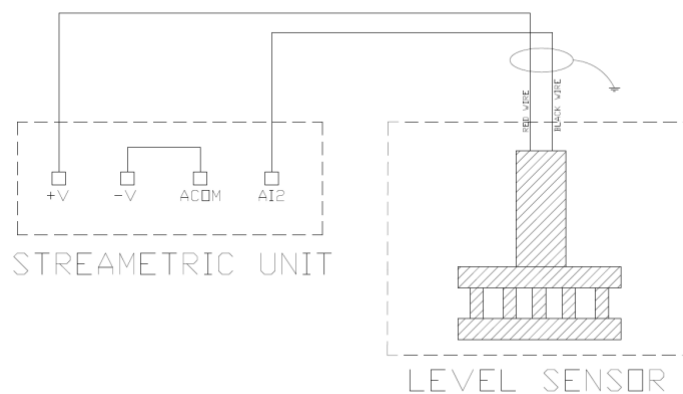

10.4 Pressure transducers

Screw the pressure transducer into the pipe to be monitored. The other end of the wire should have a red and black cable. The red cable connects to the + terminal block inside the STREAMETRIC RTU and the black wire goes to ADI1 input slot in the CWT card. A second pressure transducer can be connected similarly, with the red wire going to the + terminal on the STREAMETRIC RTU, and the black wire going to the ADI2 slot on the CWT card. Lastly connect ACOM to the - terminal block on the STREAMETRIC RTU.

